

HYDRA 7.1 SUPERSUB

Super horn-loaded subwoofer

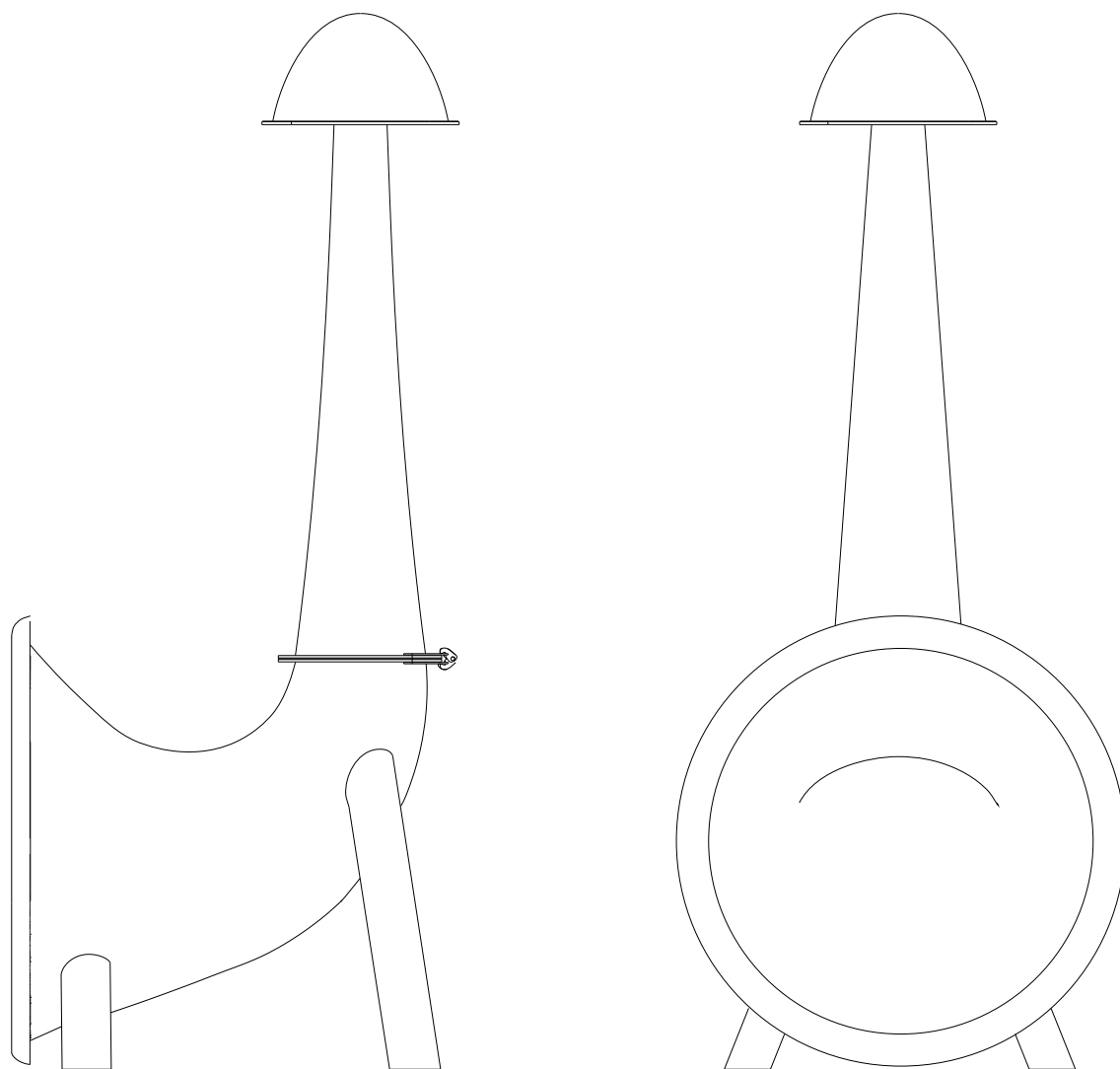

User guide

HYDRA 7.1 SUPERSUB

Super horn-loaded subwoofer

Index

- 1 Technical Specifications
- 2 Unpacking and Checking
- 3 Cables and Set-up
- 4 Installation and System Design
- 5 Accessories
- 6 Maintenance and Surface Protection
- 7 Warranty
- 8 Authenticity

1 Technical Specifications

USER GUIDE

Super horn loaded subwoofer with circular section development, characterized by extreme sensitivity, dynamics and emission power, made with an incredibly rigid and light structure in durable composite materials. Unlike all other alternatives currently available, this low frequency loudspeaker has been realized without technical and dimensional compromises, being fully developed both in terms of length and radiating surface. Thus it achieves maximum acoustic performance combined with an elegant design and personality, always keeping dynamics and control front and center. Nearly scratch proof surfaces and resistance to atmospheric agents combined with extremely high efficiency and world class sensitivity allow the Hydra to perform favorably compared with any product from the main competing brands. Hydra 7.1 guarantees the perfect loading of low frequencies in sensitivity, depth, control and SPL expressed by the usage of few watts. The most common subwoofers on the market (wooden box type) are horn loaded speakers with several internal turns, non-optimized sections and reduced length, leading to lower sensitivity, reflections that create distortions and ripples, and uneven loading. Therefore they need corrections by DSP with consequent mechanical stress caused by the excursion of the transducer, which creates more distortions while using the enormous amount of energy needed by the amplifier to obtain SPL. Hydra 7.1 uses a single hi-quality transducer of 18" (460mm). The structure is rigid, very light (considering the whole weight and the rate dB/Kg) The scenic impact is extraordinary and absolutely exclusive and unique on the professional sound market. The Hydra 8.1, folded version, is compact and reduced in height compared to the vertical version. Hydra 7.1 (vertical) and Hydra 8.1 (folded) have similar acoustic performance.

TYPE	Super horn-loaded subwoofer
FREQUENCY RESPONSE	28 Hz - 140 Hz
TOTAL SENSITIVITY	110 dB 1W/1m
NOMINAL IMPEDANCE	8 Ohm or 4 Ohm (depending on the version)
POWER HANDLING	1700 W nominal, 3400 W power continuous program
MANAGE	2 Ch amplifier to a couple of Hydra+D-SP to match to satellite. High-pass filter @25Hz, 24 dB/oct. But ;Low-pass filter @100-120Hz, 24 dB/oct. LR
RECOMMENDED AMPLIFIER	Full Fatt Audio FFA 10000 (Hydra 4 ohm version)
DISPERSION	Specialized for frontal, reduced posterior
CONSTRUCTION MATERIALS	Fiber-reinforced composite, stainless steel
FINISH	all ral color and texture on order
CONNECTORS	1x Neutrik NL4 or custom preference
DIMENSIONS	(W) 1420 mm (H) 3860 mm (D) 1670mm (W) 55 inch (H) 151 inch (D) 65 inch
WEIGHT	80 Kg (176,37 lb)

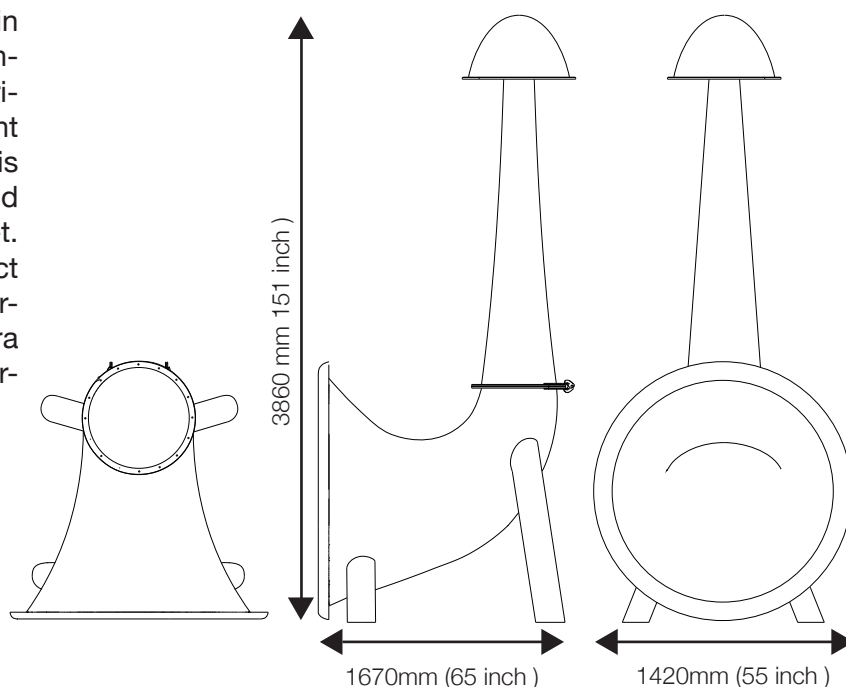

Pequod Acoustics Srl.

Via del Madonnone 25, Florence, Italy

www.pequodacoustics.com

info@pequodacoustics.com



2: Unboxing

USER GUIDE

The Hydra, like every other Pequod product, is built with high standards of control and quality. At the end of the production process and before packaging, each system is tested: acoustically measured and recorded in our company database. For each Hydra serial number, we have the related test files recorded in the archive. Before being packed in its box we complete an inspection of surfaces and structures. Units are packed into wooden crates or heavy cardboard boxes with internal foam padding before shipping.

Extraction from box:

The Hydra weighs 80 Kg (176,37 lb) each, and it's being shipped contained inside suitable wooden packaging box. Its extraction from the box is achievable by two operators, at least. When shipped disassembled, follow the instructions at the end of chapter 4 (Assembly + anchoring) , about its assembly on site. Keep the packaging for further storage or transportation, unless units are to be permanently installed.

Hydra has an input made with a female NL4 connector. Through a dedicated cable and terminated with 2 male NL4Fc connectors it is connected directly to the output of the power amplifier. The connectors are standard NL4 (+ 1 / -1 connected + 2 / -2 empty) or water proof on request.

In case of custom realization by the installer of the connection cables, we recommend specifying installation-grade Low Smoke Zero Halogen (LSZH) cables for permanent installations. The cables should use Oxygen Free Copper (OFC) of grade C11000 or above.

For distances of over 15 meters between Hydra and amplifiers we recommend increasing the section of the cable poles to 4 sq mm, to avoid excessive emission level losses. For lengths of less than 15 m, you can use 2-pole cables, each with a section of 2.5 sq. mm.

Connection diagrams:

A) 1x Hydra (see fig.below): Cable between Hydra and amp (not supplied): 2-pole cable (section 2.5 sq mm minimum per pole up to cable length of 15 m, in addition we recommend switching to 4 sq mm for pole), terminated with NI4Fc male connector (+ 1 / -1 connected and corresponding to +1 red and -1 black on the amplifier, + 2 / -2 empty) to connect to the Hydra input, which has an NL4fc female connector, standard or WP on request.

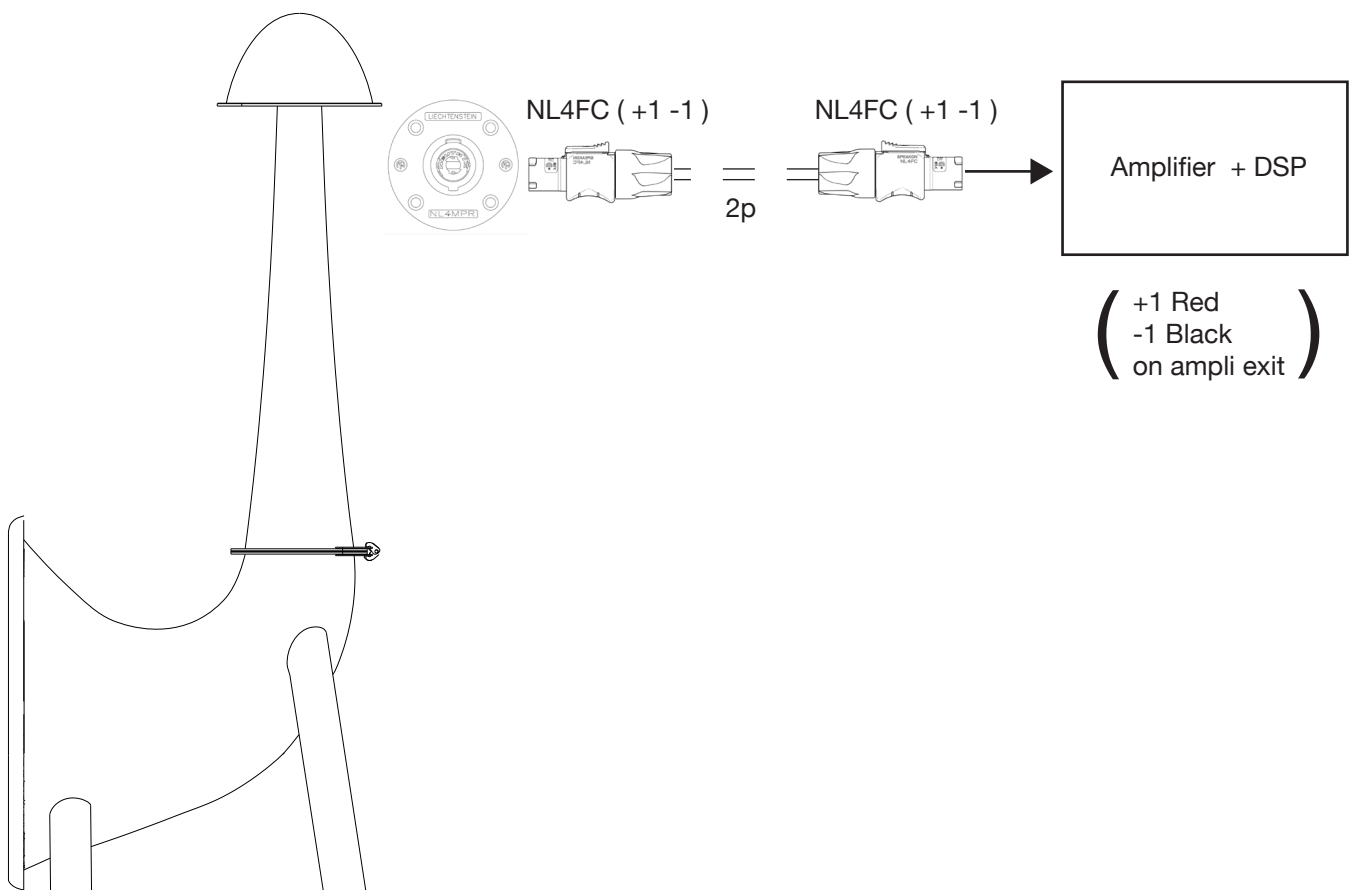

B) 2x Hydra (in parallel) (see fig. Below):

USER GUIDE

Cable between subwoofer and amp made with Y connection of 2 cables of 2 poles each, connected in parallel with each other and then connected to a 2p cable connected to amplifier.
 Terminals made with male NL4 connectors (+ 1 / -1 connected + 2 / -2 empty), terminal towards the amplifier made with male NL4 connector (+ 1 / -1 connected to +1 red and -1 black on the amplifier and + 2 / -2 empty). Sections of poles: 2.5 sq mm minimum section per pole up to cable length of 15 m, in addition we recommend switching to 4 sq mm per pole.

DSP general settings:

DSP general settings:

Band pass:

High-pass filter @25Hz, 24 dB/oct But.

Low pass filter @100-120Hz, 24 dB/oct LR.

Gain and Time Alignment : it depends on Satellite utilized

Parallel Connection

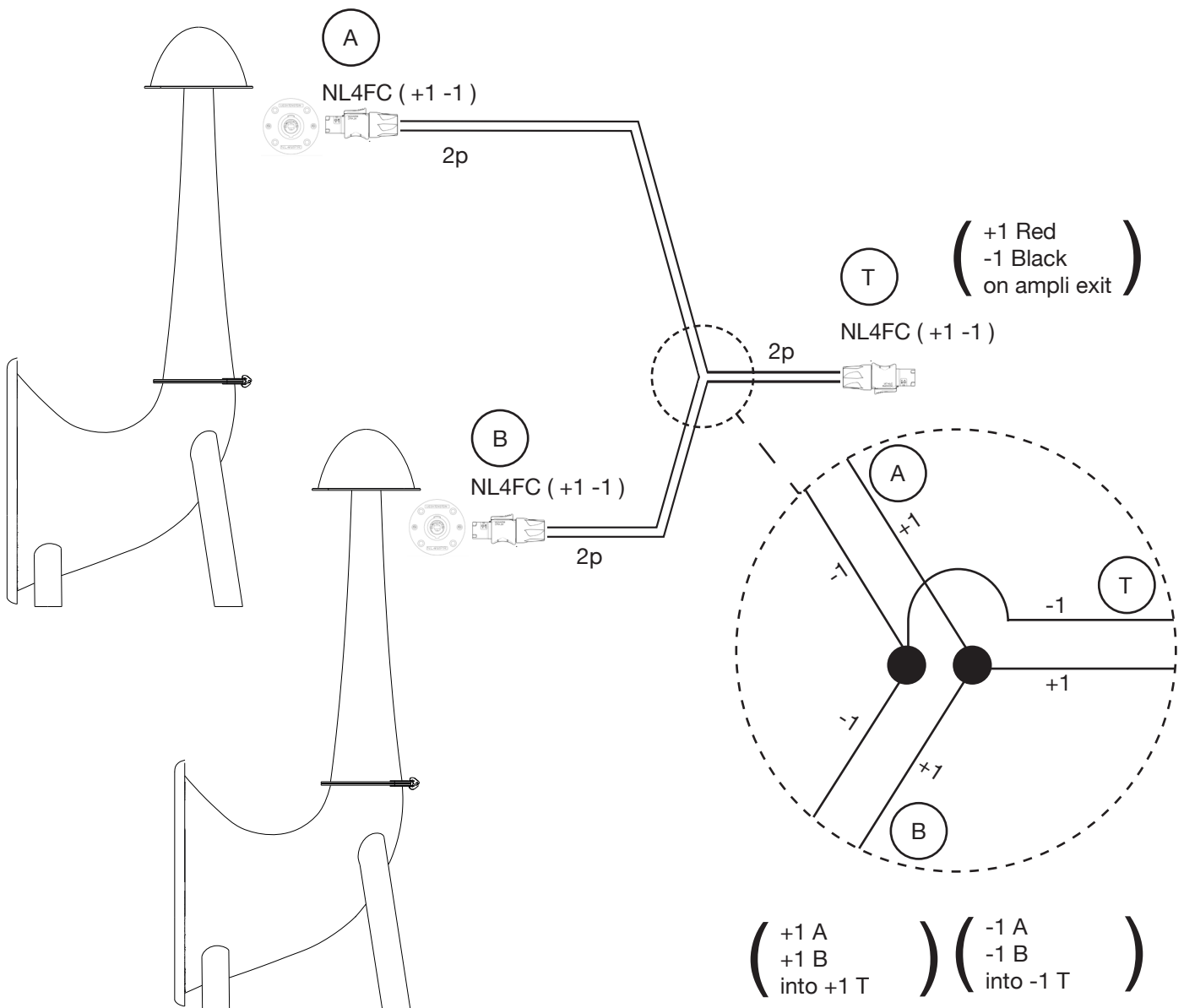

The Hydra can typically be used as a very high quality system to sonorize listening areas, such as a dance floor or for an audience of a live concert. In all cases it is necessary to use suitable satellites (Polyphemus, Swave, Kona available from the catalog Pequod) to have a full range system. Hydra represents the optimal choice as a subwoofer to be combined with the Polyphemus (SWave), to have a full range horn loaded system, of high quality and global sensitivity.

The figure shows the typical combination, with suspended Polyphemus or on the same support surface (side position)

Configuration with satellite (A up position B side position)

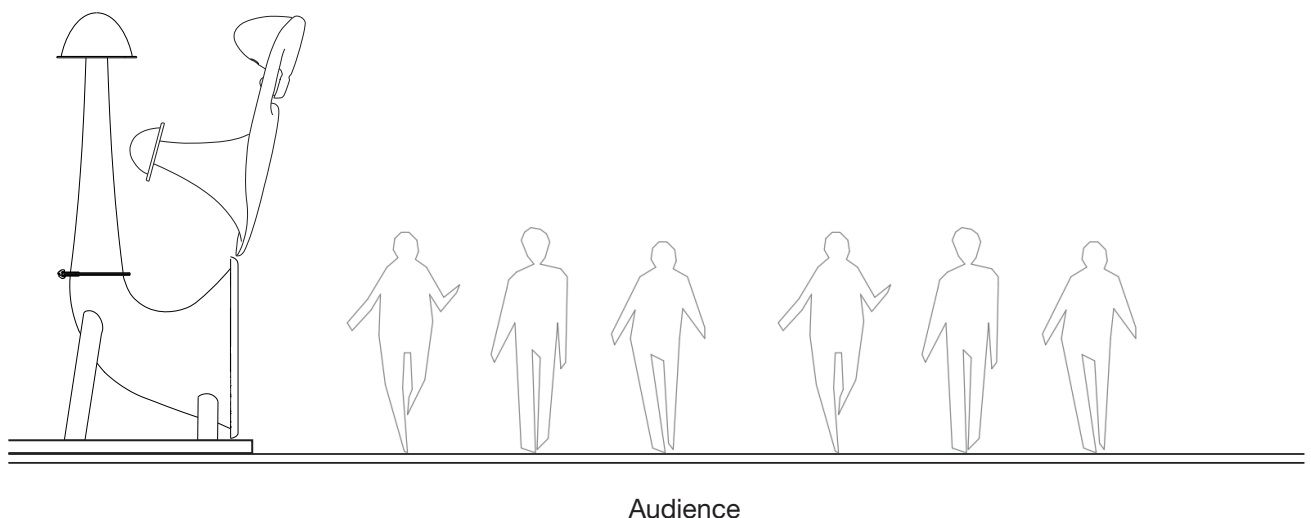
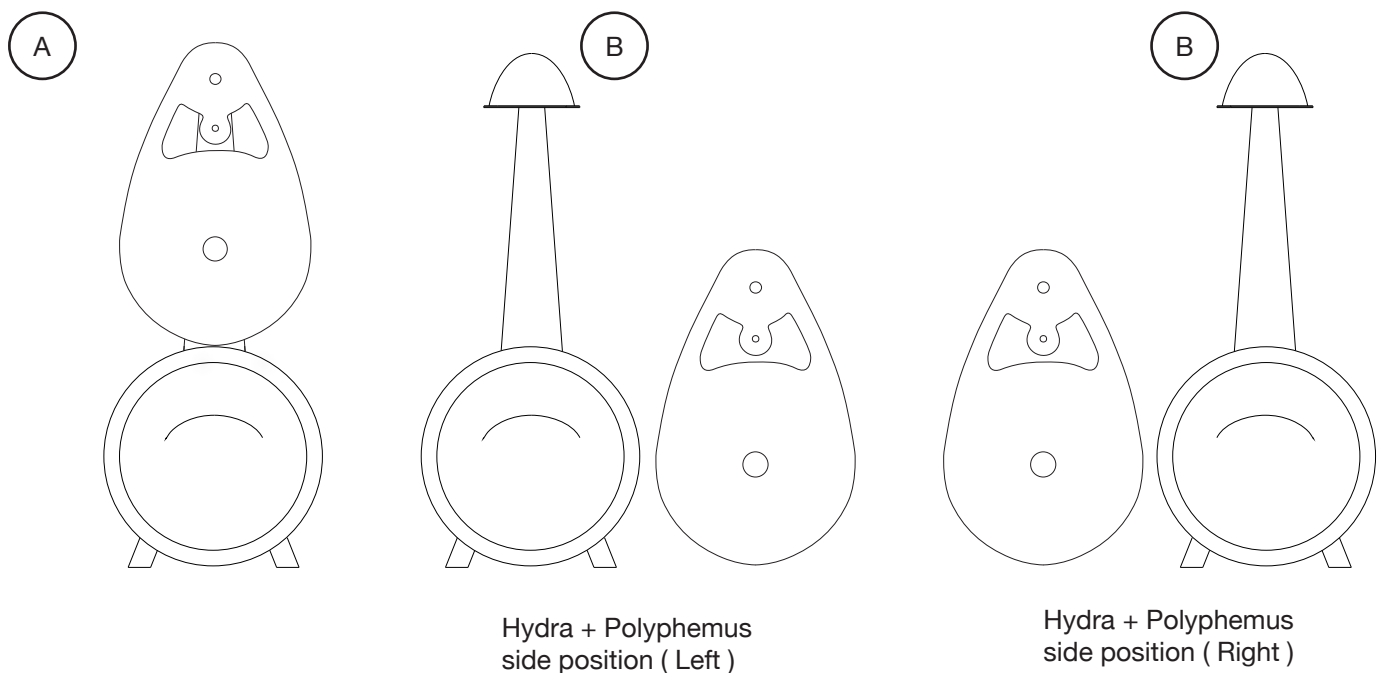

In Indoor systems:

In Indoor systems we recommend placing the Hydra against the wall (wall position) or in a corner position, to avoid harmful (for the purposes of emission regularity) reflections of acoustic waves and increase the overall performance of the system.

Corner Position

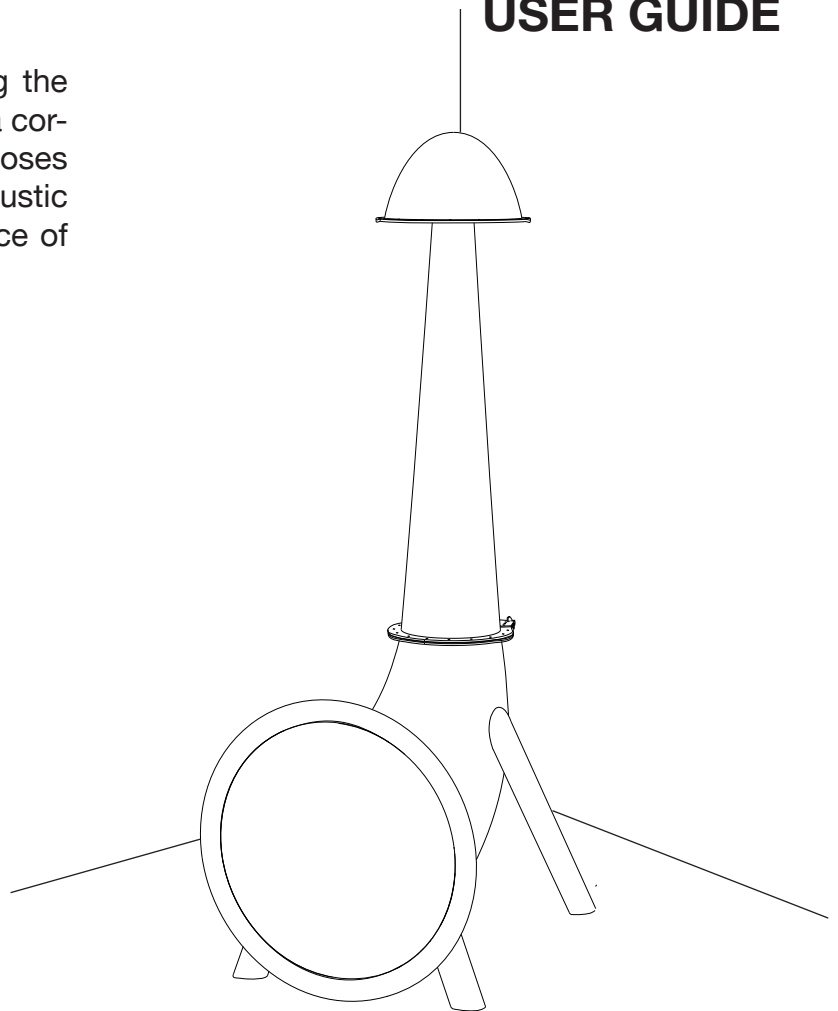
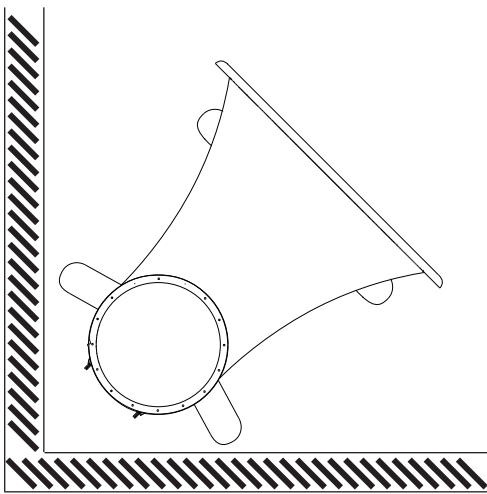

Wall Position

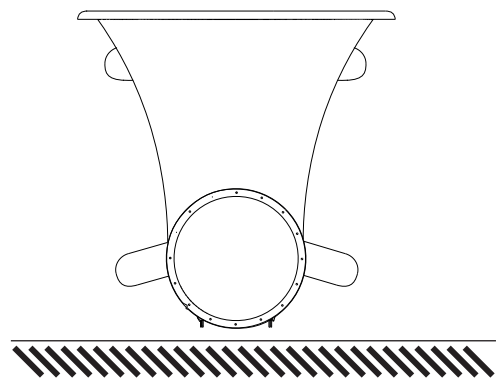
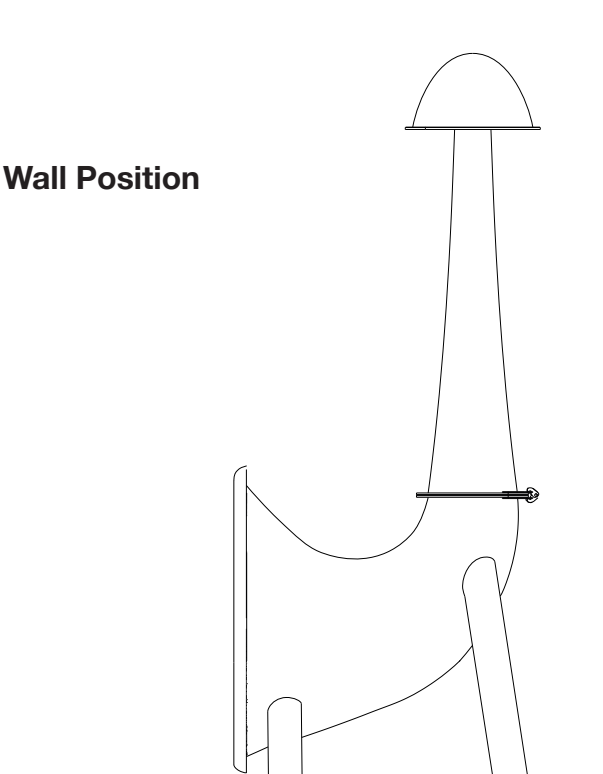

Assembly + anchoring:

USER GUIDE

As regards the assembly and possible anchoring of Hydra during installation, the straight part must be hinged at the bottom and, rotated up to the vertical by the operator (see picture), put the bolts metric thread M10 on the flange, as shown in the figure, and tighten in cross order (opposite diameters)

If necessary, there is the possibility of anchoring the 4 feet of Hydra to the ground, by means of screws, metric thread M12, screwed between the floor and threaded insert M12, placed in each foot of the product.

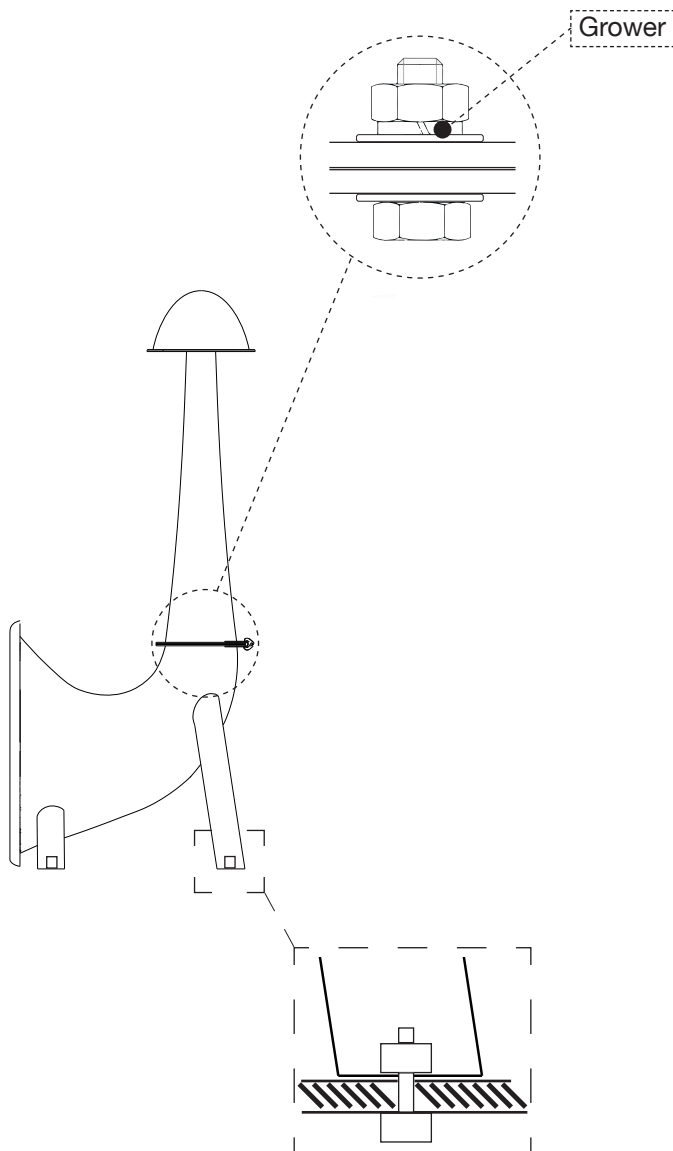
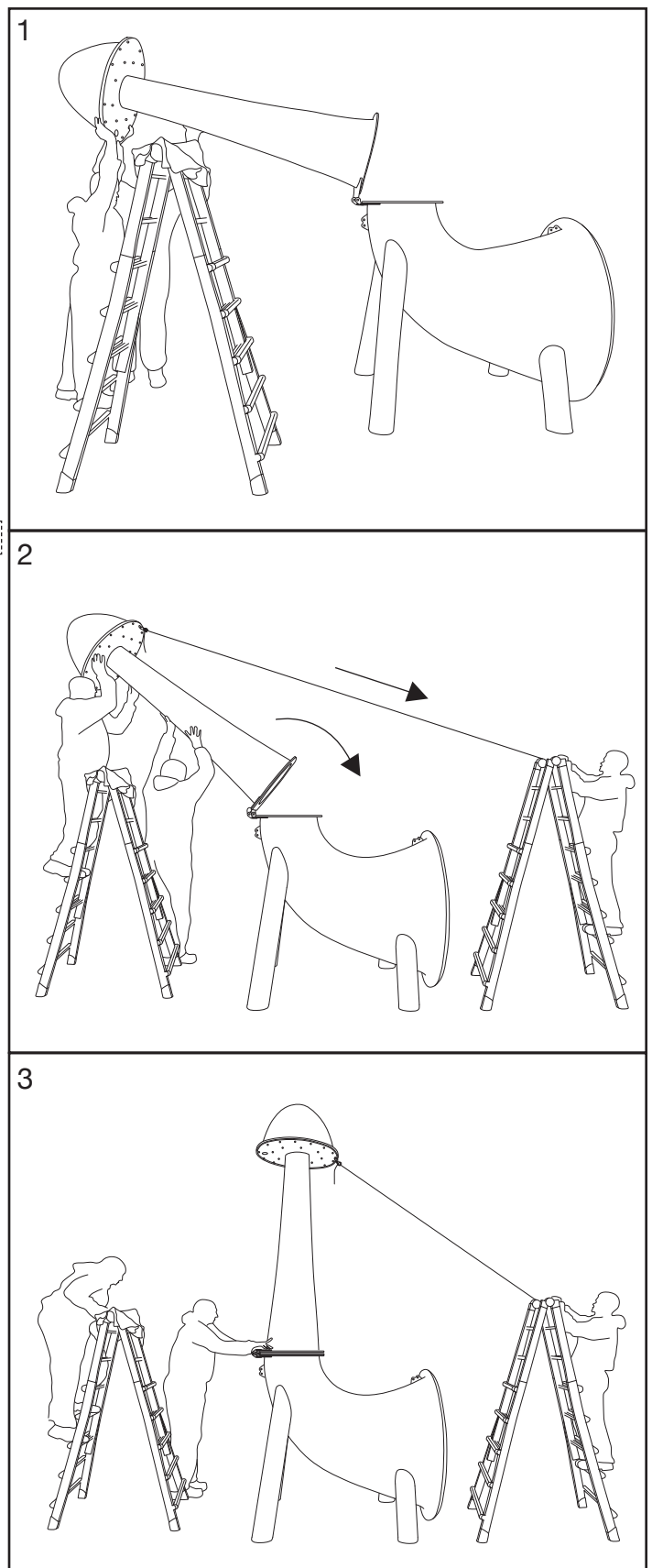

5: Accessories

USER GUIDE

In the Pequod catalog there are some accessories to be used with Hydra.

Cod. BAG01HT: Protective PVC Bag sized for the volume at the top of the Hydra, waterproof soft finish to protect from scratches and weather.

Cod. BAG01HM: Protective PVC Bag sized for the mouth of the horn system, waterproof soft finish to protect from scratches and weather.

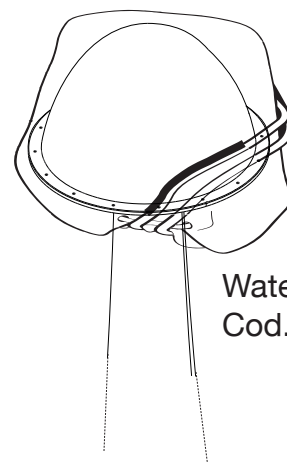

Water proof bag
Cod. BAG01HT

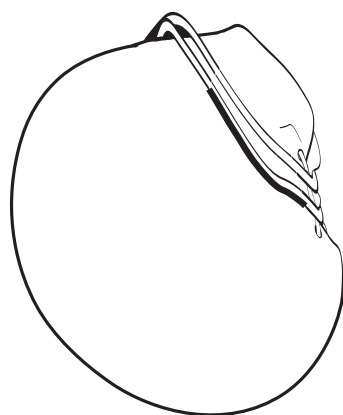

Water proof bag
Cod. BAG01HM

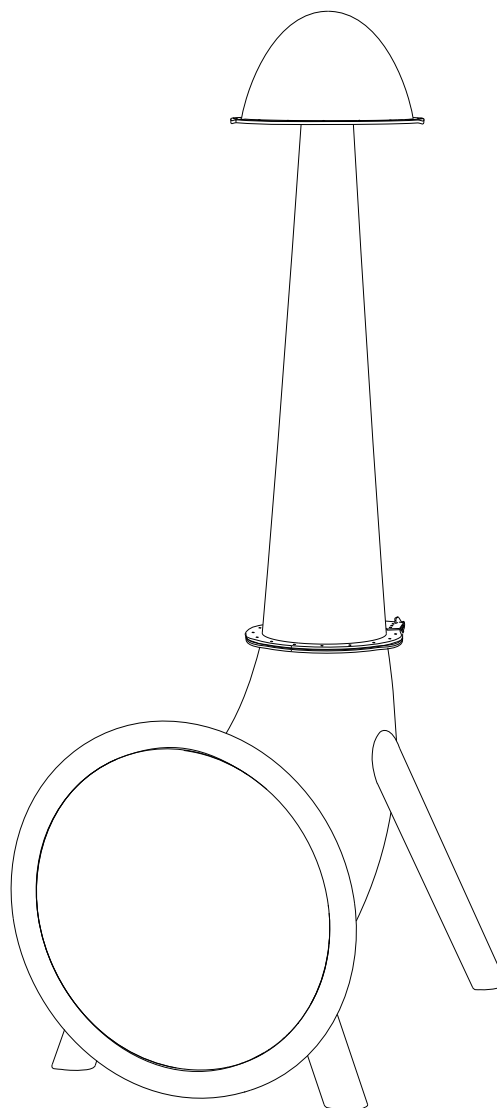

6: Maintenance and Surface Protection

All Pequod units are built from a unique high quality composite material which is inert to atmospheric agents and requires minimal regular maintenance, just a simple cleaning of the surfaces with a soft cloth dampened with alcohol.

For best practice in long term care of the composite components, and to obtain or restore a truly professional level of surface finish, we recommend using the 3M "Perfect It™" line of Gelcoat cleaners and protective waxes (above right).

Follow the instructions provided to ensure the best possible finish for your Pequod composite speaker bodies and accessories.

Many installations require Stainless Steel support structures or armatures to complete mounting and assembly of different Pequod units. For these components, we recommend cleaning with 3M™ Stainless Steel Cleaner and Polish (right).

USER GUIDE



Pequod Acoustics offers a guarantee to the original owner (person or company who purchased the product brand new) of each new Pequod product (provided it was purchased directly from Pequod or through a Pequod Acoustics Authorised Dealer/ Distributor) that it is free of defects in materials and workmanship and that each product was tested in the factory to meet or exceed all specifications declared. Each model has a test file recorded in our database, related to its serial number.

The period of limited warranty is three (3) years from the date of delivery to the original purchaser (as shown on the original invoice or sales receipt; a copy may be required as proof of warranty dates)

Pequod Acoustics will repair or replace (at its discretion) all defective parts at no charge for labor or materials; subject to following provisions:

Pequod Acoustics shall take no responsibility for repair or replacement under this warranty if:

- a) The damaged product has been subject to misuse, accident, neglect or failure to comply with normal maintenance procedures
- b) There are improper alterations or unauthorized parts or repairs.
- c) The serial number has been altered, defaced or removed and the original owner won't be able to give information related to our Anti-counterfeit authentication system (see below, section 8)

Pequod Acoustics will remedy any defect, regardless of the reason for failure (except as excluded above) by repair or replacement. Pequod Acoustics will ship the product within a reasonable time after receipt of the defective product at a Pequod Acoustics Authorised Service Centre.

How to obtain service under warranty:

If a Pequod Acoustics product requires service, the original owner must contact the Pequod Acoustics dealer who supplied the product, to receive our Return Authorisation Code (RA code), and instructions on how to return the product to the Pequod Authorised Service Centre, or to Pequod Acoustics.

The original owner must give information about:

- Problems with the product
- Serial number
- Original invoice or sales receipt
- Anti-counterfeit system (see section 8)

After receiving the RA code the owner can pack the unit in the original factory packaging if possible. Please include a note describing the problem packed together with the product. Do not send it separately.

All products being returned to the factory or service center for repairs must be shipped prepaid. Ensure safe transportation of your unit to the authorized service center

Pequod Acoustics (or an Authorised Service Centre) will initiate corrective repairs upon receipt of the returned product, in order to complete the repairs and ship back the product within a reasonable amount of time.

If the repairs made by Pequod or a Pequod Authorised Service Centre are not satisfactory to the owner, they are instructed to give written notice to Pequod.

The original owner is not entitled to recover from Pequod any incidental damages resulting from any defect in the Pequod product. This includes any damage to another product or products resulting from such a defect.

The warranty is not extended by the length of time which the owner is not engaged in active use of the product. Repairs and replacement parts provided pursuant to the warranty will be covered only by the non-expired portion of the warranty.

8: Authentication and Anti Counterfeiting Measures

USER GUIDE

Each product by Pequod Acoustics is carefully hand made using high quality components that are, by themselves, difficult to replicate. But we also protect our products using special marks on the inside and outside, which are unique and serve to authenticate original Pequod products.

Thus, each individual product has a special mark, placed in a unique position. For each product (each serial number) we keep a record of the exact position where we placed this mark.

When warranty claims are made, or other requests that require authentication of an individual Pequod product, we will ask the owner to provide a description of the identifying marker as further proof of originality.